

Tenon Jig Plans



This handy jig was designed to hold the work piece for cutting tenons on the table saw and for general use on the drill press. This jig, by use of T-Track, permits practically unlimited arrangement of the stops and hold down clamps. Plus, it's easy to make a custom stop for any odd shapes you may need to work with. It's simple and easy to make. All you need to do is clamp the work piece in the jig, set the saw blade height and slide the jig along the rip fence. Simply set the stop blocks to align the work piece for the cut and clamp with a couple of toggle clamps or hold down clamp as shown above. Note: The red colored surface you see in the picture is medium grit sandpaper glued to the jig surface. Sandpaper helps keeps the work piece from sliding.

Table of Contents

Please read and follow all tool manufacturers safety and operating instructions before operating equipment. Always wear eye and hearing protection.

Materials List	1
Tenon Jig Parts	2
Tenon Jig Hole Layout	3
Tenon Jig Assembly Instructions	4

Introduction

Thank you for visiting BobsPlans.com. I believe you will find this Tenon Jig to be a rewarding and useful project. The base, front, and face sections are made of 1/2" plywood. The gussets are made of any 3/4" stock. You'll need two 12" long strips of T-Track. and some knobs, clamps, and T-Track bolts.

This project has four 5/16" mounting holes that are spaced so it can be mounted to the drill press table for which free plans are also offered on BobsPlans.com. It can also be used with our table saw jig but you will need to drill another hole or two in the base to line up with the table saw jig's T-Track. It was originally designed for use in making spokes for the 14" wagon wheel for which we offer plans. But it comes in handy any time there is a need to hold a small piece of stock for either drilling or sawing.

I highly recommend you glue sandpaper to the surfaces of the face of this tenon jig. The sandpaper greatly increases the holding power of the clamps.

Sources for the T-Track and clamps you'll need are provided on the sponsor's page.

Materials List

Page 1

Tenon Jig Materials List

Qty	Item Name	Size	Material
1	Base	11 1/2" X 6"	1/2" Plywood
1	Front	12" X 6"	1/2" Plywood
2	Face A	1" X 12"	1/2" Plywood
1	Face B	2 1/2" X 12"	1/2" Plywood
2	Gussets	3 1/2" X 4"	3/4" Stock
2	T-Track	12"	Aluminum T-Track
2	Knobs	5/16" threads	N/A
2	T-Track Bolts	Assorted	
2	Hold Down Clamps	N/A	N/A

Tenon Jig Parts Drawings

Page 2

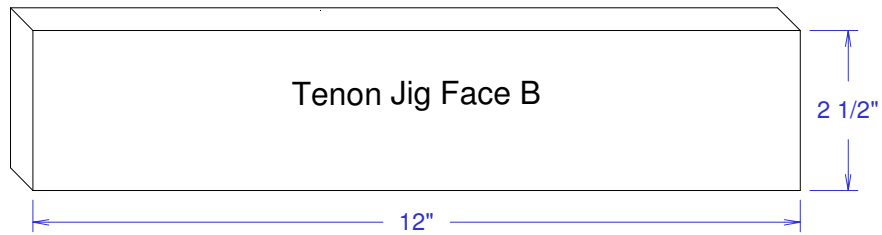
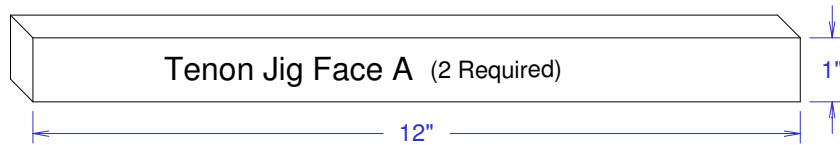
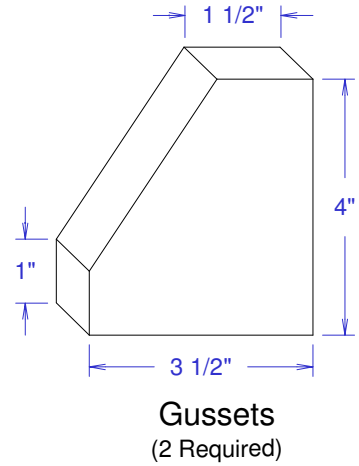
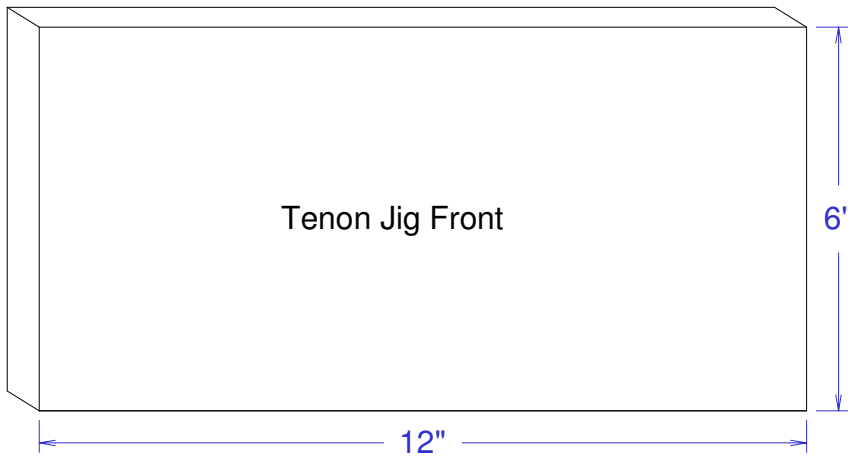
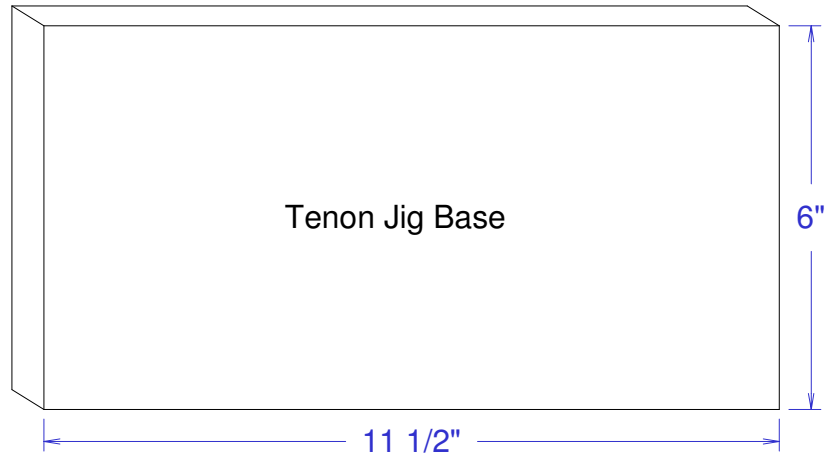

Tenon Jig Hole Layout Drawings

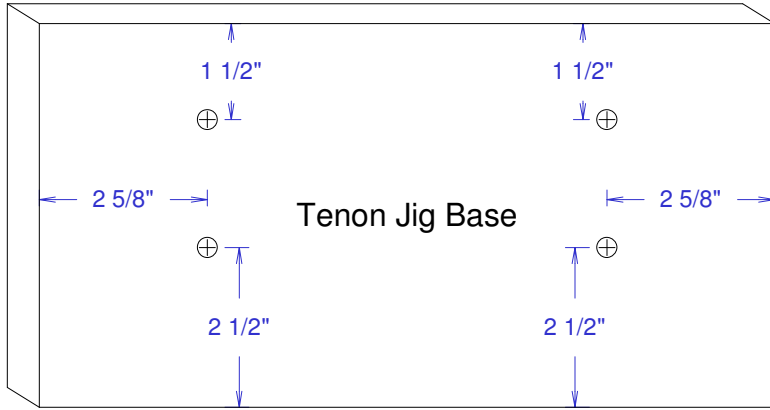

Drill four 5/16" diameter holes for T-Track bolts as shown above.

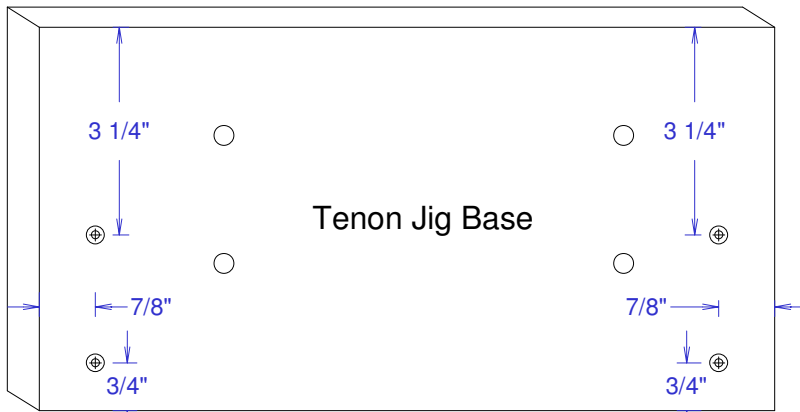

Drill four 9/64" diameter holes for the gusset screws, Then countersink them on the underside of the base.

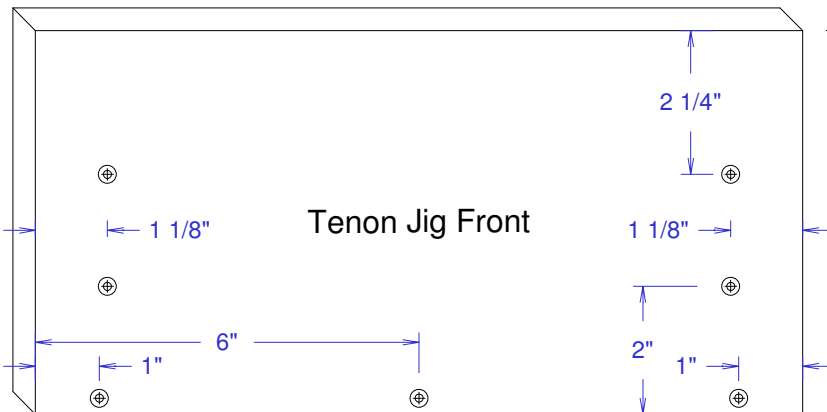

Drill and countersink four 9/64" diameter holes for the gusset screws. Then drill and countersink three 9/64" diameter holes for attaching the front to the base. These three holes are 1/4" from the bottom.

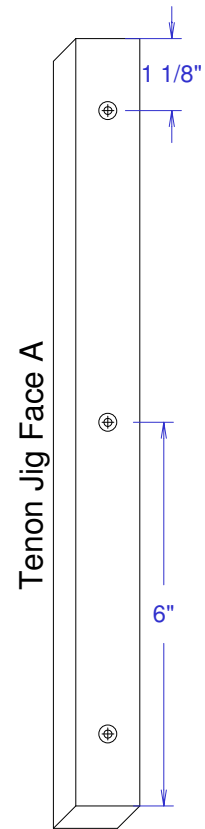

Drill and countersink three 9/64" diameter holes for # 6 screws.

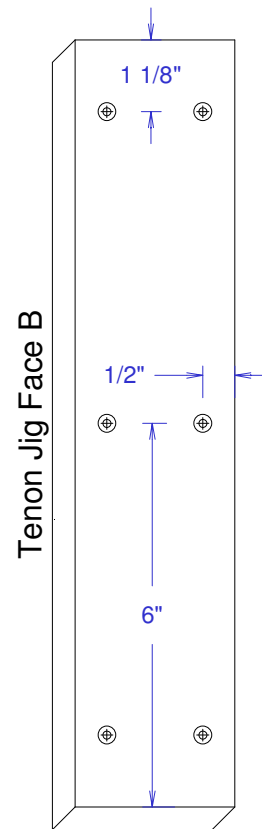

Drill and countersink six 9/64" diameter holes for # 6 screws.

Tenon Jig Assembly Instructions

Page 4

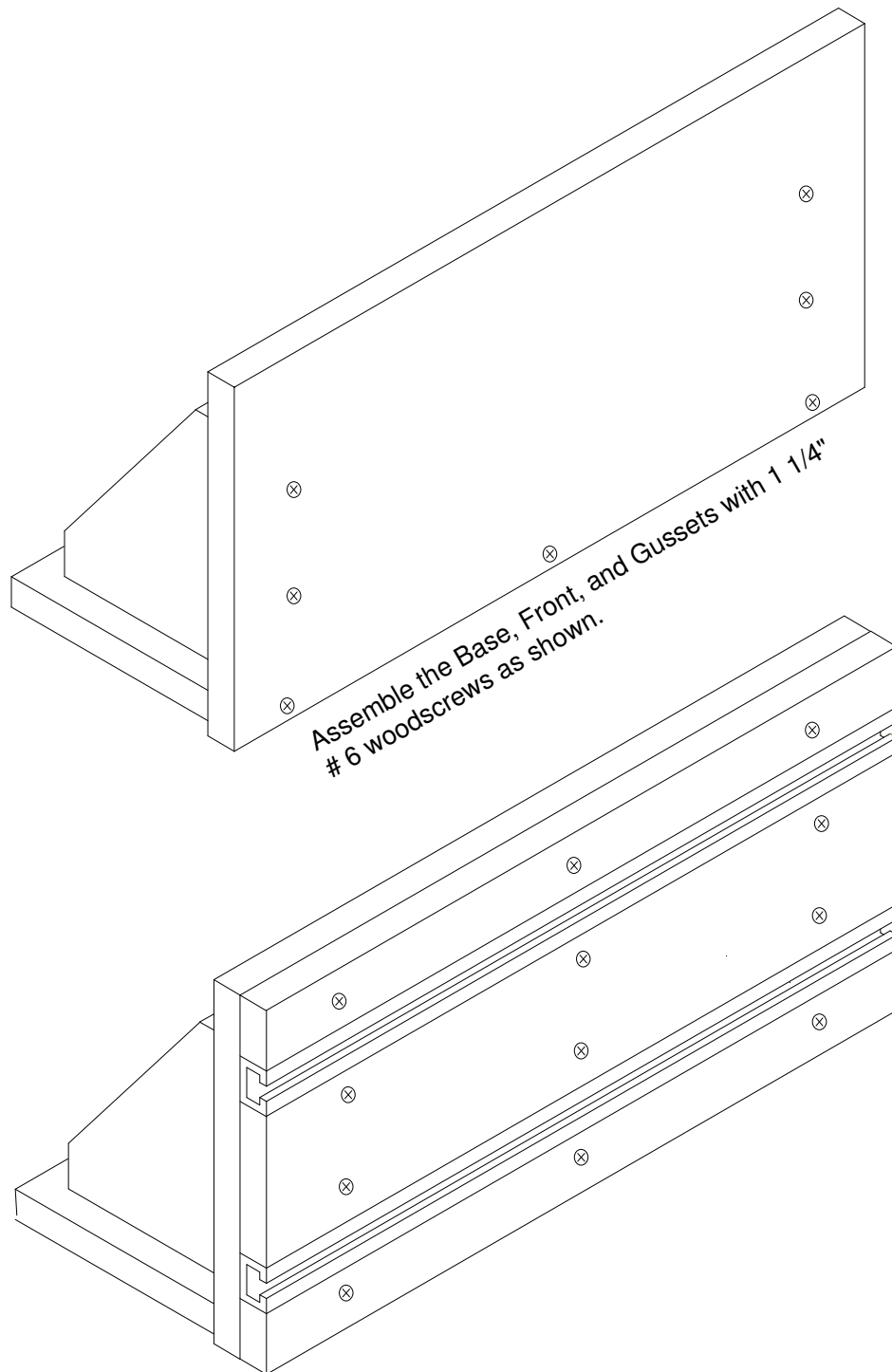

Drill and countersink holes for # 6 screws 1 1/8" from each end of the T-Track so the screws will align with the gussets. Attach the three Face pieces and T-Track to the Front with 1" # 6 flat head screws. Finally, cut strips of 100 grit sandpaper the size of the face pieces and glue them to the surface. This will keep the work piece from moving during use. If the points of the screws come through the back, you might want to file them flat as screw points can cut your fingers. This completes your Tenon Jig.